

FEATURES

- Completely self-contained heating and cooling package
 - No outside condensing unit
 - No external refrigerant lines
 - No separate cooling coil
 - No separate venting system
- Pre-wired and pre-charged
- Individually metered and controlled
- Slide-out cooling chassis
- Internal vent system (direct vent)

REFRIGERANT SYSTEM

- R410a Refrigerant
- High efficiency compressor
- Copper tubing with enhanced fin coils

HEAT EXCHANGER

- Standard aluminized steel tubular heat exchanger
- Optional 409 stainless steel heat exchanger

CABINET

- Attractive, neutral-toned finish

BLOWER

- Multispeed motor for wide airflow range
- PSC permanently lubricated motor for low maintenance and maximum efficiency
- Dynamically balanced blower with resilient motor mounts for smooth and quiet operation
- Internal washable filter

CONTROLS

- Color coded wiring for easy service

INSTALLATION

- Easy to install and service

HWC4 Model Vintage™ Units Gas Heating / Electric Cooling Packaged Thru-the-Wall Units

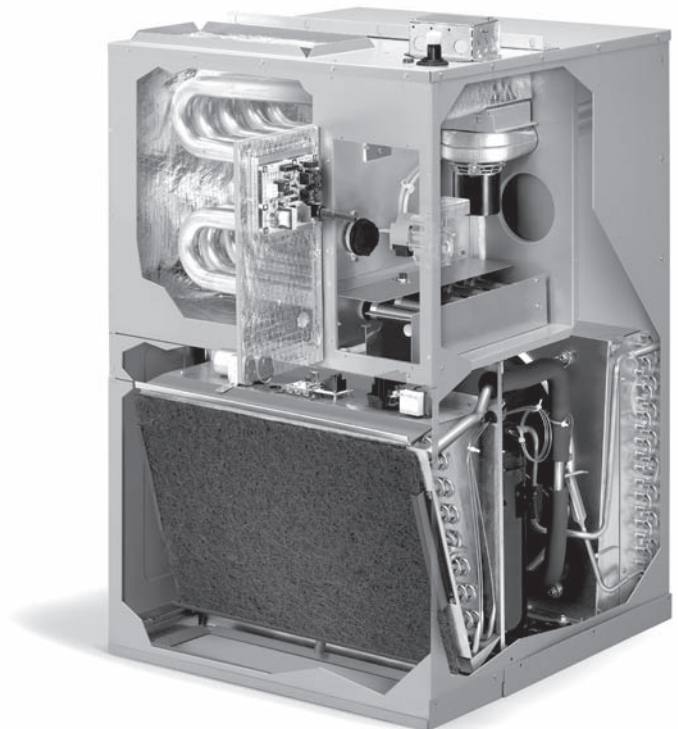

WARRANTY

- 5 year limited warranty on all parts
- 10 year warranty on aluminized heat exchanger
- 20 year warranty on stainless steel heat exchanger

Model Number Guide

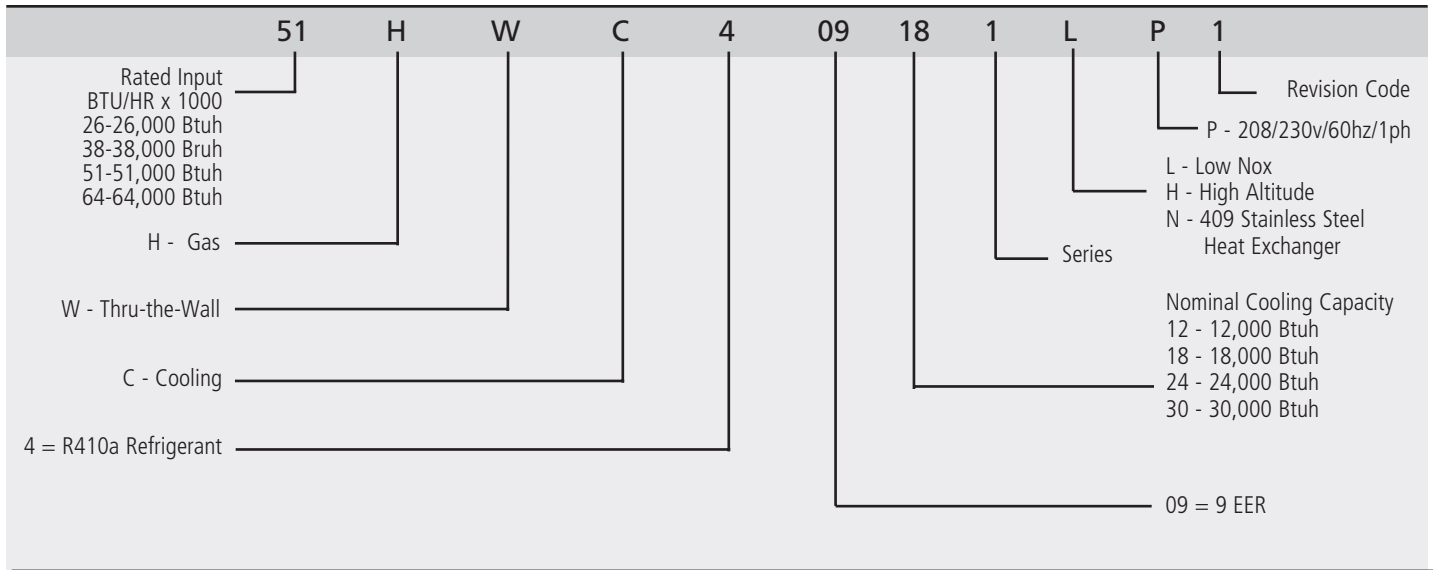

Electrical and Physical Data

Model	Voltage/ Hz/ Phase	Voltage Range	Min. Circuit (amps)	Max. Fuse/ HACR Brkr.	Compressor		Outside Fan				Indoor Blower			Refrig. Charge (oz.)	Weight (lbs.)
					Rated Load Amps	Locked Rotor Amps	Dia. (in.)	Nom. RPM	Rated Load Amps (amps)	Rated HP	Wheel Dia. x Width	Rated Load Amps	Rated HP		
26HWC4-09-121	208-230/60/1	197 - 253	11.6	15	6.8	45.0	18	1075	0.9	1/8	10 X 4	2.2	1/3	39	325
38HWC4-09-121															
38HWC4-09-181	208-230/60/1	197 - 253	14.3	20	9.0	48.0	18	1075	0.9	1/8	10 x 4	2.2	1/3	43	350
51HWC4-09-181															
64HWC4-09-181															
38HWC4-09-241	208-230/60/1	197 - 253	20.6	30	13.5	58.3	18	1075	1.6	1/4	10 x 4	2.2	1/3	52	360
51HWC4-09-241															
64HWC4-09-241															
51HWC4-09-301	208-230/60/1	197 - 253	20.2	30	13.1	74.0	18	1075	1.6	1/4	10 x 4	2.2	1/3	80	380
64HWC4-09-301															

Blower Performance

Model	Blower Speed	CFM @ ext. static pressure - in. w.c. with filter(s)			
		0.2	0.3	0.4	0.5
HWC4-09-121	Hi	650	615	575	540
	Med	475	450	425	400
	Low	415	405	390	380
HWC4-09-181, 241, 301	Hi	875	825	775	725
	Med	850	805	760	710
	Low	630	605	575	550

Performance

Model	Cooling				Heating			
	Btuh	EER	S/T	CFM	Input Btuh	Output Btuh	AFUE	Temp. Rise Range °F
26HWC4-09-121	11,400	9.0	.72	400	26,000	20,000	80.0%	40-70
38HWC4-09-121					38,000	30,000	80.0%	40-70
38HWC4-09-181	17,000	9.0	.74	650	38,000	30,000	80.0%	40-70
51HWC4-09-181					51,000	40,000	80.0%	40-70
64HWC4-09-181					64,000	50,000	80.0%	50-80
38HWC4-09-241	22,400	9.0	.74	800	38,000	30,000	80.0%	40-70
51HWC4-09-241					51,000	40,000	80.0%	40-70
64HWC4-09-241					64,000	50,000	80.0%	50-80
51HWC4-09-301	28,000	9.0	.70	825	51,000	40,000	80.0%	40-70
64HWC4-09-301					64,000	50,000	80.0%	50-80

Sound Ratings

Model	Sound Rating (dBA)
26HWC4-09-121P	76
38HWC4-09-121P	
38HWC4-09-181P	76
51HWC4-09-181P	
64HWC4-09-181P	
38HWC4-09-241P	80
51HWC4-09-241P	
64HWC4-09-241P	
51HWC4-09-301P	80
64HWC4-09-301P	

Accessories

Description	Kit Number	Where Used
Wall Sleeve	CA-239	All HWC4's
Decorative External Louver	ALVR42-1	All HWC4's
Chassis Adapter Kit	ADAPT420	All HWC4's
Wall Sleeve Adapter Kit	A242	All HWC4's
LP Kit	ALPKT389-2	All HWC4's
Low Ambient Kit	ALOAMB505-1	All HWC4's

Dimensions (in.)

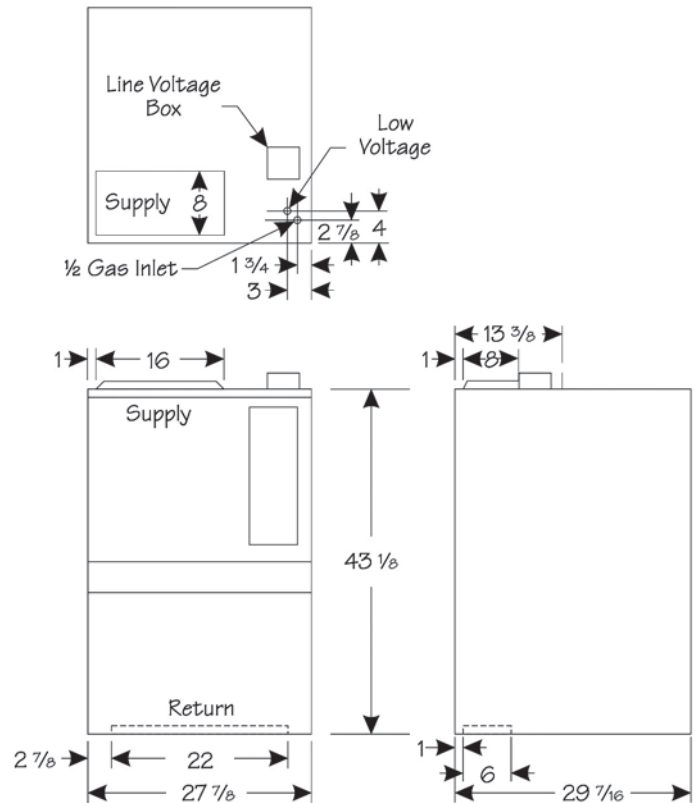

Wall Sleeve (in.)

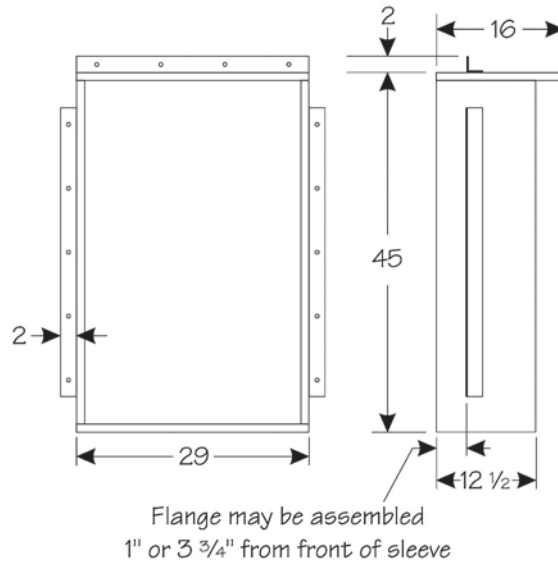

215 Metropolitan Drive
West Columbia, SC 29170
800-448-5872
Product Support 866-282-7257

All specifications and illustrations
subject to change without notice
and without incurring obligations.