

INSTALLATION AND MAINTENANCE INSTRUCTIONS

MHP4 Series Magic-Pak

Self-Contained Heat Pump[®]

Save these instructions for future reference

WARNING

Improper installation, adjustment, alteration, service, or maintenance can cause injury or property damage. Refer to this manual. For assistance or additional information, consult a qualified installer or service agency.

WARNING

For your safety, do not store or use gasoline or other flammable vapors and liquids in the vicinity of this or any other appliance. Such actions could result in property damage, personal injury, or death.

WARNING

These units are not approved for mobile home applications. Such use could result in property damage, personal injury, or death.

WARNING

Installation and servicing of air conditioning equipment can be hazardous due to internal refrigerant pressure and live electrical components. Only trained and qualified service personnel should install or service this equipment. Installation and service performed by unqualified persons can result in property damage, personal injury, or death.

TABLE OF CONTENTS

INSTALLATION	2
OPERATION	8
MAINTENANCE	10
ACCESSORIES	11
WIRING DIAGRAMS	14

WARNING

The unit must be installed with approved wall sleeve and grille accessories for safe operation. Improper installation could result in property damage, personal injury, or death.

Manufactured By
Allied Air Enterprises Inc.
A Lennox International Inc. Company
 215 Metropolitan Drive
 West Columbia, SC 29170



CAUTION

The installation of this appliance must conform to the requirements of the National Fire Protection Association; the National Electrical Code, ANSI/NFPA No. 70 (latest edition) in the United States; the Canadian Electrical Code Part 1, CSA 22.1 (latest edition) in Canada; and any state or provincial laws or local ordinances. Local authorities having jurisdiction should be consulted before installation is made. Such applicable regulations or requirements take precedence over the general instructions in this manual.

INSTALLATION

General

These instructions explain the recommended method of installation of the MHP4 heat pump unit and associated electrical wiring.

This unit is designed and approved for use as a self-contained air to air heat pump system.

These instructions, and any instructions packaged with mating components and/or accessories, should be carefully read prior to beginning installation. Note particularly any **CAUTIONS** or **WARNINGS** in these instructions and all labels on the units.

These instructions are intended as a general guide only, for use by qualified personnel and do not supersede any national or local codes in any way. Compliance with all local, state, provincial, or national codes pertaining to this type of equipment should be determined prior to installation.

Inspection

Upon receipt of equipment, carefully inspect it for possible shipping damage. If damage is found, it should be noted on the carrier's freight bill. Take special care to examine the unit inside the carton if the carton is damaged. File a claim with the transportation company. **If any damages are discovered and reported to the carrier do not install the unit, as claim may be denied.**

Check the unit rating plate to confirm specifications are as ordered.

Application Limitations			
Outdoor Ambient Air Temperature °F			
Minimum DB		Maximum DB	
Cool		Cool	Heat
65		115	75
Indoor Ambient Air Temperature °F			
Minimum		Maximum	
DB/WB	DB	DB/WB	DB
Cool	Heat	Cool	Heat
62/57	50	90/72	80

Table 1

Limitations

The unit should be installed in accordance with all national and local safety codes.

Limitations of the unit and appropriate accessories must also be observed.

The outdoor fan is designed to operate against no more than .10" W.C. static pressure.

Minimum and maximum operation conditions must be observed to assure maximum system performance with minimum service required. Refer to Table 1 for the application limitations of the unit.

Location

WARNING

The unit must be installed with approved wall sleeve and grille accessories for safe operation. Improper installations could result in property damage, personal injury, or death.

For information on wall sleeves and grille accessories, see **ACCESSORIES** beginning on page 11.

The design is certified for thru-the-wall or up-to-the wall (inside wall) installation only. The interior portions of the unit may be surrounded by a closet with clearances to combustible material held to 0" at the sides, top, and front of the plenum. All servicing and cleaning of the unit can be performed from the front. If installed in a closet or utility room, provide 25" clearance in front for service if the door to the room is not in line with the front of the unit (see Figure 1). **Accessibility clearances must take precedence over fire protection clearances.**

The outside of the unit may be flush with the face of the exterior wall, and it should not be obstructed with trees, landscape materials, or building structure. Unit can be installed recessed with appropriate wall sleeve accessories. There is no minimum clearance required on locating the unit to an interior corner of a building.

If the unit is installed in a residential garage, it must be located or protected to avoid physical damage by vehicles. The unit must be installed so that no electrical components are exposed to water.



CAUTION

This unit must be installed level to allow for proper drainage of the unit base pan and indoor drain pan.

Minimum Clearances

Clearance to combustibles is 0" at the side, top, and front of plenum. If accessibility clearances are greater than clearances to combustibles, accessibility clearances take precedence.

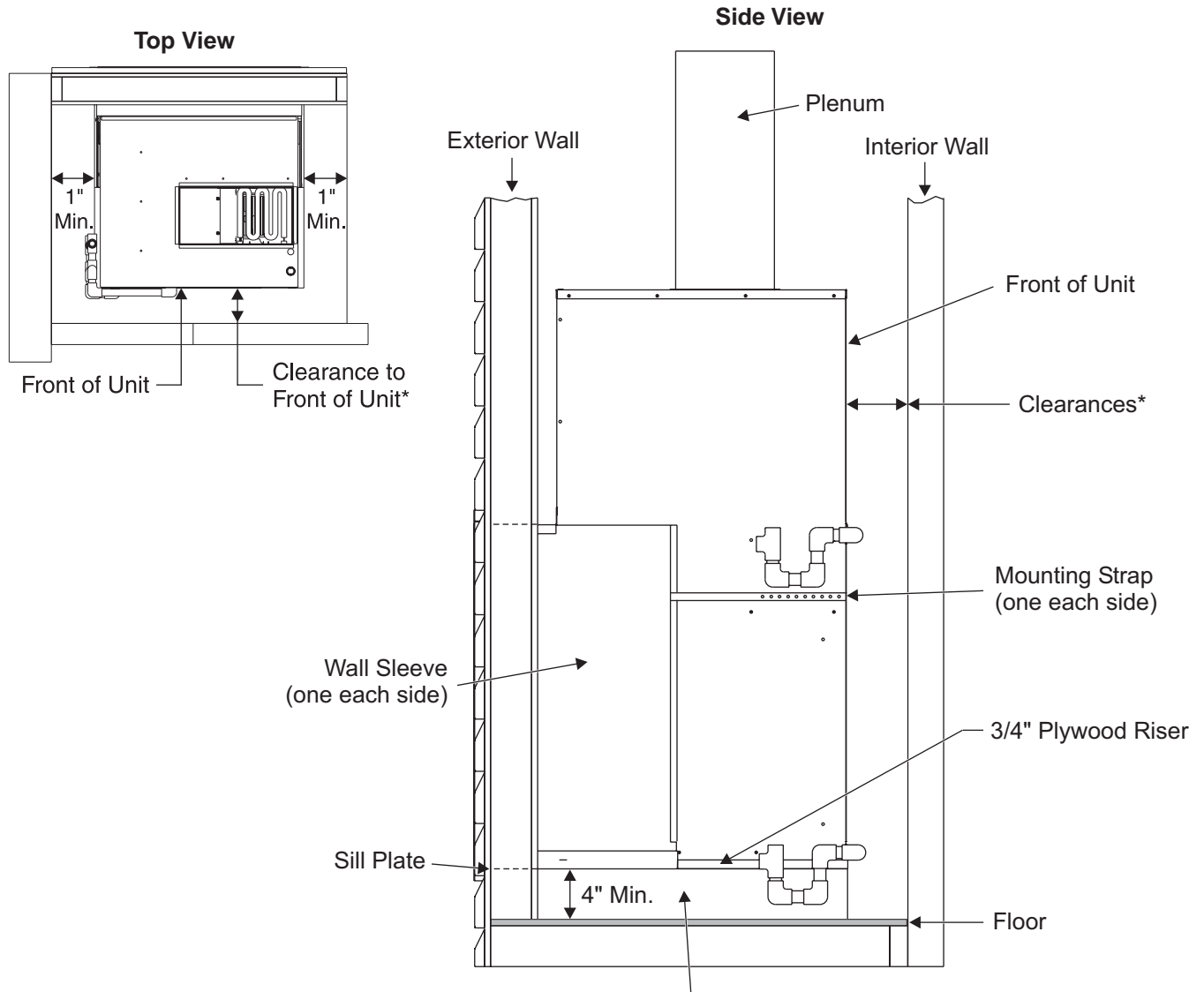
The front of the unit must be accessible for service. If the unit is enclosed, providing a door or access panel opposite the front of the unit is the preferred method of providing access. The door or access panel must be at least 30" wide (centered on the unit) and as tall as the unit. If a return duct is not installed, in order to provide adequate return air the minimum clearance required between the front of the unit and the door or access panel is 4" for 43" tall cabinets and 5" for 48" and 56" tall cabinets.



Platform (field supplied) - Must be level with sill plate of hole in exterior wall unit must be supported by platform.

* With no return duct installed, minimum clearances to the front of the unit are 4" for 43" tall cabinets and 5" for 48" and 56" cabinets. If a return duct is installed, enough clearance must be provided for the drain trap installation.

IMPORTANT

The unit must be installed with approved wall sleeve and grille accessories for safe operation. Improper installations could result in property damage, personal injury, or death.

Figure 1

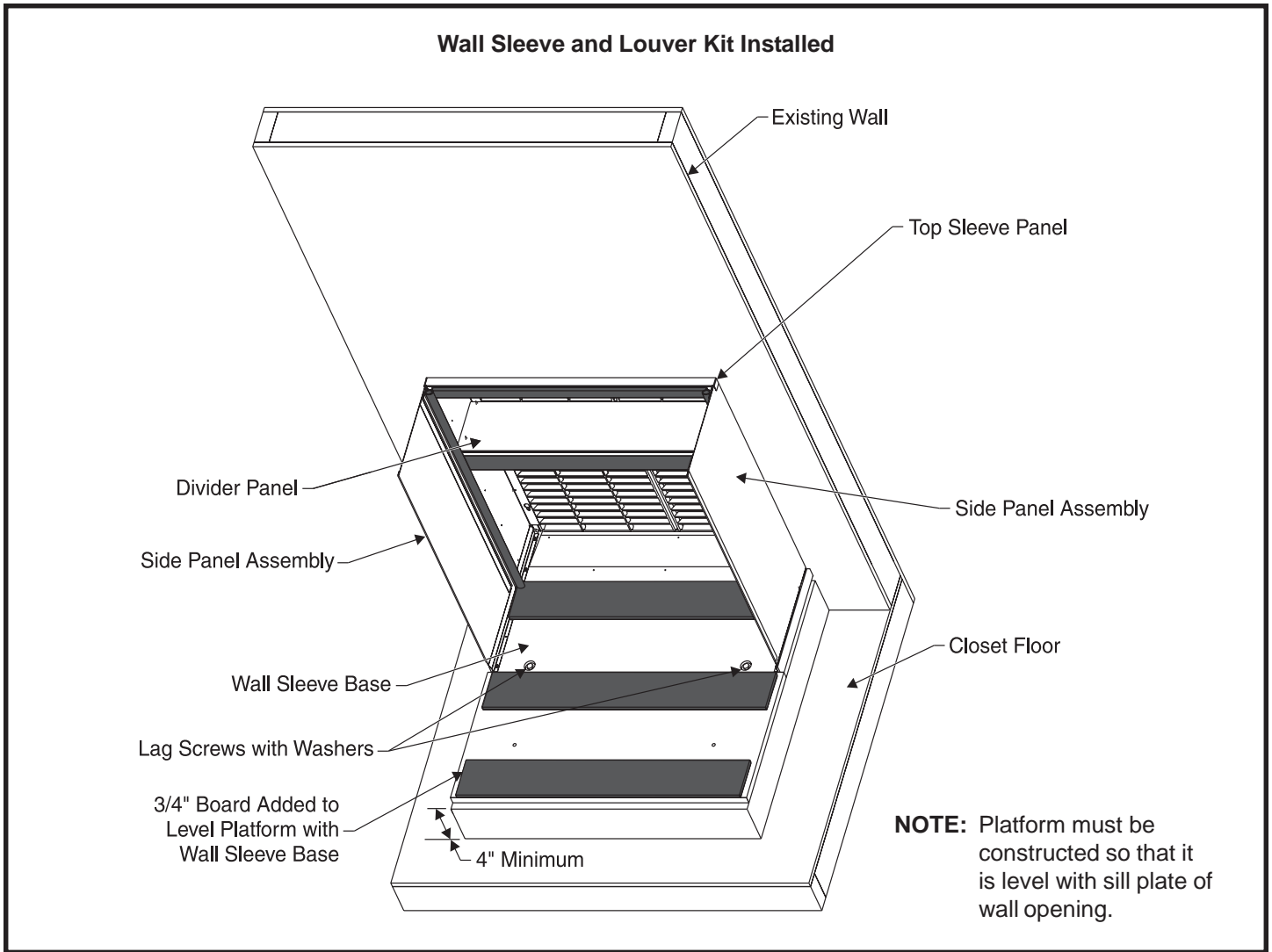

Figure 2

Wall Sleeve and Louver Grille Installation

Refer to installation instructions included with the wall sleeve kit and the louver grille kit along with Figure 2 for guidance in assembling and installing the wall sleeve and louver grille.

CAUTION

The sleeve is not intended as the sole support for the unit. An additional support must be provided for adequate support (see Figure 2).

Installing and Securing Unit to Wall Sleeve

1. Make sure the gaskets attached to the sleeve are not damaged.
2. Verify divider panel is positioned properly. Figure 3 shows the correct position for 48" and 56" tall units (flange

- pointing up). For 43" tall units, the divider panel should be positioned so the flange points down.
3. Place MHP4 unit into wall sleeve. **Lift leading end of unit and walk unit onto sleeve.** Once in sleeve, lower the unit into position. This prevents damage to the base pads. Assure that the unit is level and completely seated against the gaskets on the wall sleeve.
4. Use the two installation brackets to secure the unit to the wall sleeve (see Figure 4). The units are shipped with the brackets placed in the return air compartment. Hook each bracket into the front edge of the wall sleeve side. Position the bracket so it can be bent around the front corner of the unit. Remove one of the two screws in that position on the unit. Line up one of the holes in the installation bracket with the screw hole and attach the bracket to the unit with that screw. Make sure to fasten tight enough that the seal is maintained. Trim off excess bracket if applicable.

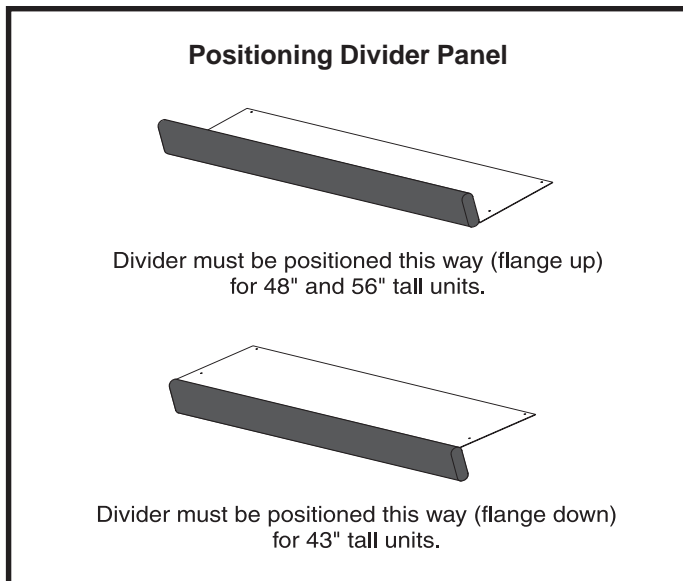

Figure 3

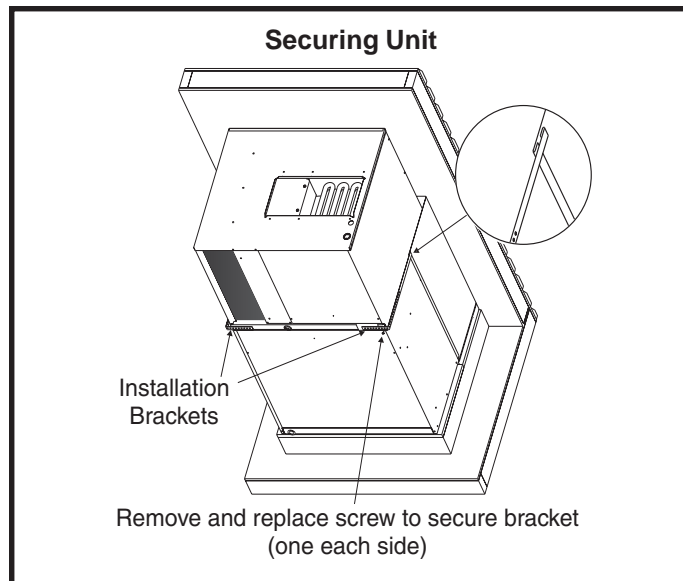

Figure 4

Inspect the fit up of the unit to the wall sleeve. Verify that the gaskets of the wall sleeve make a complete seal to the unit paying particular attention to top and bottom corners of unit to sleeve seal. Caulk if needed.

Ductwork

Ductwork should be designed and sized according to the methods in Manual Q of the Air Conditioning Contractors of America (ACCA).

Check unit air supply outlet for debris before making ductwork connections.

It is recommended that supply and return duct connections at the unit be made with flexible joints. If flexible ducts are used, a 6" sheet metal starter collar is required.

The supply and return air duct systems should be designed for the CFM and static requirements of the job (see Table 3 on page 6). **They should not be sized to match the dimensions of the duct connections on the unit.** The return duct should be sealed to the unit casing and terminate outside the space containing the unit.

CAUTION

Do not screw into the side of the drain pan, or into the indoor coil or heat strip.

The filter should be cleaned at least three times during each of the heating and cooling seasons, or more frequently if unusual conditions are encountered. To clean the washable filter, shake filter to remove excess dirt and/or use a vacuum cleaner. Wash filter in soap or detergent water and replace after filter is dry. It is not necessary to oil the filter after washing.

If an installation is made in which it is more desirable to mount the filter exterior to the unit, in the return duct work or elsewhere, the washable filter can be used or replaced with a disposable filter. If a disposable filter is used, use the information provided in Table 2 when sizing the disposable filter.

Model Number	Filter Area
MHP*12	192 square inches
MHP*18	288 square inches
MHP*24	384 square inches
MHP*30-36	480 square inches

* 9 and 10 SEER models

Table 2

Air Filter

All indoor return air must be filtered. A washable filter is furnished with the unit, located in the return air opening. If return duct is installed, provisions must be made to accommodate filter servicing.

Blower Performance

Model	Blower Speed	External Static Pressure (in.w.c. w/filter)				
		0.1	0.2	0.3	0.4	0.5
MHP4-9-12 MHP4-9-18 MHP4-9-24	Low	450	440	425	400	370
	Medium/Low	700	690	680	650	600
	Medium/High	810	800	790	770	730
	High	940	920	875	850	810
MHP4-9-30	Low	620	600	580	560	535
	Medium/Low	840	820	785	750	700
	Medium/High	975	940	870	825	760
	High	1075	1000	930	880	800
MHP4-9-36	Low	750	720	680	650	620
	Medium/Low	1000	980	950	920	880
	Medium/High	1100	1080	1050	1020	980
	High	1270	1230	1200	1170	1130
MHP4-10-18 MHP4-10-24	Low	450	440	425	400	370
	Medium/Low	700	690	680	650	600
	Medium/High	810	800	790	770	730
	High	940	920	875	850	810
MHP4-10-30	Low	630	620	610	580	550
	Medium/Low	900	890	850	800	750
	Medium/High	1070	1030	1000	920	840
	High	1220	1150	1100	1030	920

Table 3

Condensate Drain

Provisions must be made to properly drain the indoor and outdoor drain pans of this appliance.

Indoor drain connection: 1/2" NPT to 3/4" PVC fitting (schedule 40). Outdoor drain connection: 3/4" NPT to 3/4" PVC fitting (schedule 40). Both drains must be trapped as shown in Figure 5. The drain line should pitch gradually downward at least 1" per 10' of horizontal run to open drain.



Use thread sealant on the threaded fittings. Install threaded fittings by hand only. **Do not over torque the fittings.**

Do not thread metal condensate fittings to unit drain pan.

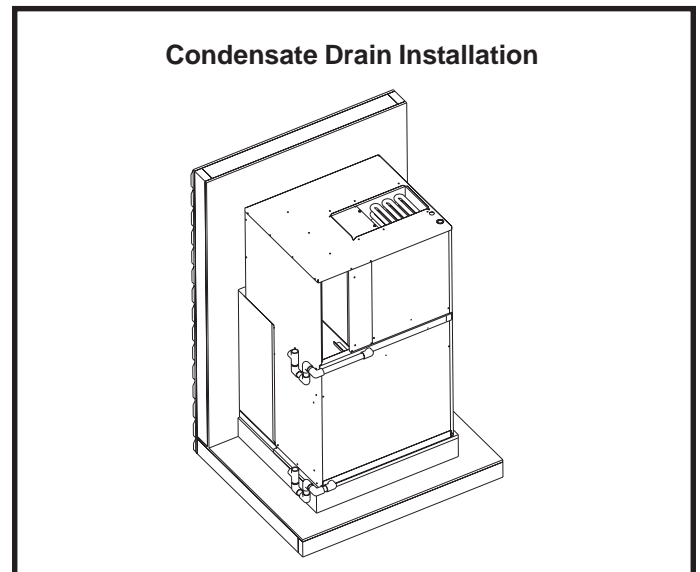

Figure 5

If local codes require the use of metal condensate lines, do not thread metal fittings into the unit drain pan. A 1/2" x 3/4" threaded plastic nipple is available from the manufacturer as

a kit (see **ACCESSORIES** on page 11). Thread the 1/2" end of the nipple into the unit drain pan and make the field connection to the 3/4" end.

Fresh Air Intake (Fresh Air Models Only)

On fresh air capable models (designated by the FA in the model number – 7MHP4-10-30FA-1), up to 5% fresh air is drawn into the unit from outside when the indoor blower comes on.



The location of fresh air capable models must conform to the requirements of National Fire Protection Association NFPA No. 54 in regards to proximity of forced air inlets to flue gas terminals. Improper installation could result in personal injury or death.

To access the fresh air intake feature, the threaded cap must be removed from the fresh air intake pipe (see Figure 6). The fresh air intake pipe is located at the rear of the unit return air intake. When not in use, cap should be placed nearby in the air intake area in case it is needed in the future.

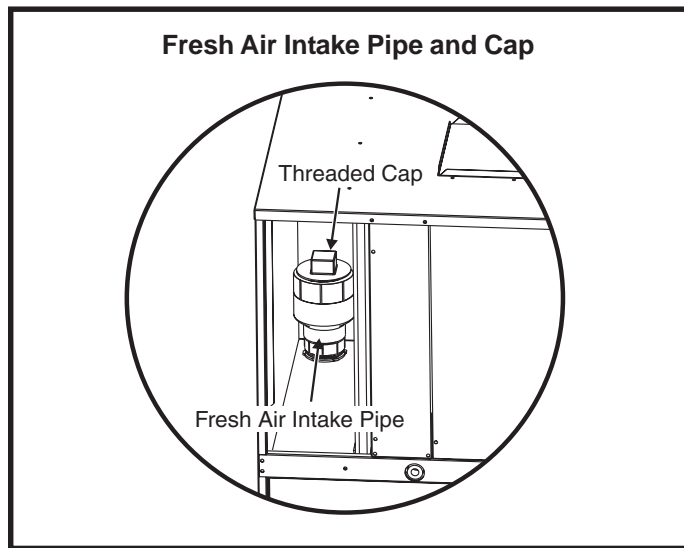

Figure 6

Thermostat

The room thermostat should be located on an inside wall where it will not be subject to drafts, sun exposure, or heat from electrical fixtures or appliances. Follow manufacturer's instructions enclosed with the thermostat for general installation procedures. Color-coded insulated wires (#18 AWG) should be used to connect the thermostat to the unit.

Electrical Connections

All wiring must be done in accordance with the National Electrical Code (NEC), ANSI/NFPA No. 70 (latest edition); Canadian Electrical Code CSA C22.2 Part 1 (latest edition); or local codes, where they prevail. Any alteration of internal wiring will void certification and warranty.

Units are factory wired for a 230 volt power supply. If power supply is 208 volts, it will be necessary to change a wire connection on unit transformer from 240 volt terminal to 208 volt terminal as shown on the wiring diagram.

Use wiring with a temperature limitation of 75°F minimum. Run the 208 or 230 volt, 60 hertz electric power supply through a fused disconnect switch to the control box of the unit and connect as shown in the wiring diagram located on the inside of the control access panel.

The unit must be electrically grounded in accordance with local codes or, in the absence of local codes, with the National Electrical Code ANSI/NFPA No. 70 (latest edition) or CSA C22.2 Part 1 (latest edition).

Power supply to the unit must be NEC Class 1 and must comply with all applicable codes. A fused disconnect switch should be field provided for the unit. The switch must be separate from all other circuits. If any of the wire supplied with the unit must be replaced, replacement wire must be of the type shown on the wiring diagram. Electrical wiring must be sized to minimum circuit ampacity marked on the unit. **Use copper conductors only.** Each unit must be wired with a separate branch circuit and be properly fused.

NOTE: Some MHP4 models require two separate power supply circuits. See the unit wiring diagrams and rating plates for specifications.

OPERATION

Sequence of Operation

Upon initial “power up” to unit, there is a 3-minute time delay to the compressor contactor (R to Y). Any 24V interrupt (R, C) to the defrost control will initiate the 3-minute delay to the contactor.

Cooling

When the thermostat is in the cooling mode, the O circuit is powered which energizes the reversing valve. Upon cooling demand, the thermostat closes circuit R to Y and G. Closing R to Y closes the unit contactor, starting the compressor and outdoor fan. The thermostat automatically closes R to G circuit which also brings on the indoor blower at the same time. Upon satisfying cooling demand, the thermostat will open the above circuits and open the main contactor, stopping the compressor and outdoor fan. The unit is equipped with a time delay; the blower will continue to operate for 90 seconds which improves system efficiency.

Heating

Upon heating demand, the thermostat closes circuit R to Y, which closes the unit contactor, starting the compressor and outdoor fan. The reversing valve is not energized in the heating mode. The thermostat again automatically brings on the indoor fan at the same time. The second stage of the thermostat closes circuit R to W, which closes the unit sequencers, bringing the auxiliary electric heat on. Upon satisfying heating demand, the thermostat opens the above circuits and stops unit operation.

NOTE: The 7.2 and 10 kW heats strips offer a W1 and W2 thermostat connection. Taking advantage of the two heat strip circuits requires a 3-stage thermostat (Y for heat pump, W1 for electric heat stage 1, and W2 for electric heat stage 2). If a 2-stage thermostat is used, “pigtail” W1 and W2 wires together when connecting the thermostat wires at the unit.

Defrost Cycle

If the outdoor ambient conditions are such that frost forms on the outdoor coil, the defrost control monitors the need for, initiates, and terminates defrost cycles as necessary to maintain system performance. The defrost control is time/temperature initiated and temperature terminated with a maximum defrost time (time-out) of 10 minutes. Time between defrost cycles is preset at 60-minute intervals at the factory, but can be field adjusted between 30, 60, or 90 minutes. To field adjust time between defrost cycles, place defrost time plug in the proper position (see Figure 8).

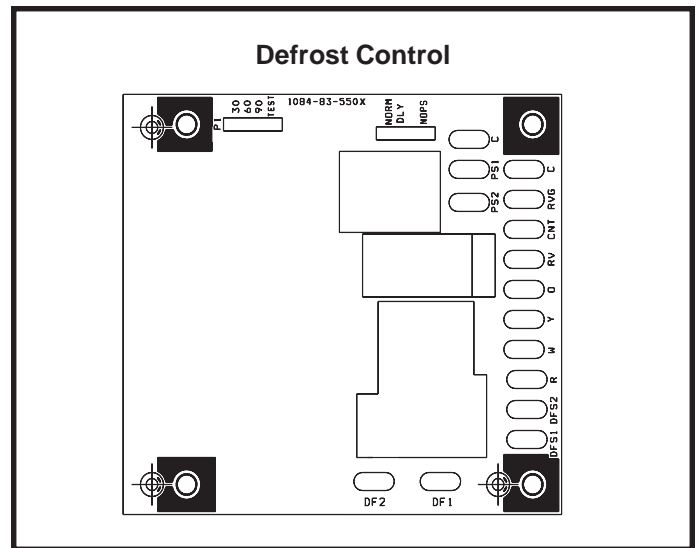

Figure 7

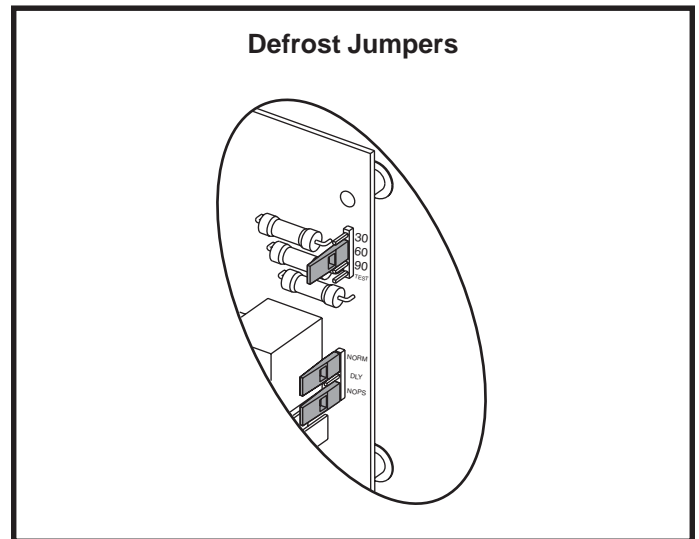

Figure 8

Defrost control will initiate a defrost cycle if the time period has elapsed and the defrost sensor sees a temperature below freezing. At the start of a defrost cycle, the defrost control will energize the reversing valve solenoid, shifting the reversing valve and de-energizing the outdoor fan. The defrost relay will also close, energizing auxiliary heat for increased comfort during defrost. The unit will remain in defrost until the defrost sensor has determined that the frost has been removed from the coil or a 10-minute time period has elapsed.

The defrost control is also equipped with a set of pins to aid in the troubleshooting of the defrost system (see Figure 8).

The following is a brief outline of the testing of the defrost system.

1. Defrost sensor must be closed, 32°F or below. If temperatures are such that the switch will not close, jumper between defrost sensor terminals on the defrost control.
2. Start system in heating operation.
3. Jumper test pins. A 1/4" quick connect terminal crimped onto a solid wire or brazing rod works well for a test jumper. Closing test pins speeds up time interval by a factor of 256.

Defrost Control Setting	Defrost Test Cycle Time
30 minutes	7 seconds
60 minutes	14 seconds
90 minutes	21 seconds

After closing test pins and appropriate cycle time has elapsed, the reversing valve should shift to defrost mode and the outdoor fan should stop. After 2 seconds of defrost operation, the reversing valve should shift back to heating operation and the outdoor fan should start.

Quiet Defrost Feature

The defrost control in this appliance is equipped with a quiet defrost feature. With the jumper pin set at the DLY position, at the start of the defrost cycle, the defrost control will energize the reversing valve solenoid and de-energized the outdoor fan, and de-energize the compressor circuit a period of 10 seconds. The result is a much quieter defrost cycle.

CAUTION

For reliable operation, all MHP9A12 models must always have the jumper pin in the NORM position.

All units have the jumper pin set at the NORM position. PS1 and PS2 terminals: These appliances are not equipped with a pressure switch in the refrigeration system. Therefore, the jumper on the NOPS pin is factory installed and required.

System Performance

For maximum performance of this heat pump system, the operating temperatures and pressures should be checked and superheat determined at Standard ARI test conditions of 82°F outdoor – 80°F indoor dry bulb/67°F wet bulb. If superheat measured deviates from the values given in Table 4, refrigerant charge should be adjusted accordingly for maximum performance.

Suction Superheat	
Magic-Pak® Model	Suction Superheat @ ARI Conditions 82° OD 80° IDDB/67° IDWB
MHP4-09-12	15-18
MHP4-09-18	9-11
MHP4-09-24	17-19
MHP4-09-30	11-13
MHP4-09-36	23-25
MHP4-10-18	8-10
MHP4-10-24	16-18
MHP4-10-30	24-26

Table 4

MAINTENANCE



Disconnect all electrical power to the unit before conducting any maintenance procedures. Failure to disconnect the power could result in personal injury or death.

Periodic inspection and maintenance normally consists of changing or cleaning filters and (under some conditions) cleaning the coils.

Filter

Inspect the filter once a month. Replace disposable filter or clean the washable filter as necessary (a minimum of three times each heating or cooling season is recommended). Do not replace washable filter with a disposable filter unless an installation was made in which the filter was mounted exterior to the unit.

Motors

The indoor and outdoor fan motors are permanently lubricated and require no maintenance.

Outdoor Coil

Foreign material should not be allowed to accumulate on the outdoor coil surface or other parts in the air circuit. Cleaning should be as often as necessary to keep the coil clean. To clean the coil, remove the lower access panel and blow out debris by using compressed air or water. **Be sure power to unit is shut off before using water to clean the coil.**

Care should be used when cleaning the coils so that the coil fins are not damaged.

Outdoor Base Drain

Foreign material should not be allowed to clog the drain hole. Inspect and clear drain opening prior to heating season.

ACCESSORIES

Kit No.	Description	Used With
LVRPWHT-1	Polypropylene Louver Kit (White)	MHP4-09-12, 18, 24, & 30/MHP4-10-18 & 24
ALVRPWHT-2	Polypropylene Louver Kit (White)	MHP4-10-30/MHP4-09-36
ALVRPSAN-1	Polypropylene Louver Kit (Sandstone)	MHP4-09-12, 18, 24, & 30/MHP4-10-18 & 24
ALVRPSAN-2	Polypropylene Louver Kit (Sandstone)	MHP4-10-30/MHP4-09-36
ALVRPBGE-1	Polypropylene Louver Kit (Beige)	MHP4-09-12, 18, 24, & 30/MHP4-10-18 & 24
ALVRPBGE-2	Polypropylene Louver Kit (Beige)	MHP4-10-30/MHP4-09-36
ALVRPTPST-1	Polypropylene Louver Kit (Toupestone)	MHP4-09-12, 18, 24, & 30/MHP4-10-18 & 24
ALVRPTPST-2	Polypropylene Louver Kit (Toupestone)	MHP4-10-30/MHP4-09-36
ALVRAL-1	Extruded Aluminum Louver Kit	MHP4-09-12, 18, 24, & 30/MHP4-10-18 & 24
ALVRAL-2	Extruded Aluminum Louver Kit	MHP4-10-30/MHP4-09-36
ALVRAL-3	Extruded Aluminum Louver Kit (45" Height)	MHP4-09-12, 18, 24 & 30/MHP4-10-18 & 24
ALVRAL-4	Extruded Aluminum Louver Kit (45" Height)	MHP4-10-30/MHP4-09-36
ALVRAL-5	Extruded Aluminum Louver Kit (50" Height)	MHP4-09-12, 18, 24, & 30/MHP4-10-18 & 24
ALVRAL-6	Extruded Aluminum Louver Kit (50" Height)	MHP4-10-30/MHP4-09-36
ASLEEVE-3 ²	Wall Sleeve Kit (45" Louver)	MHP4-09-12 & 18
ASLEEVE2-1	2" Wall Sleeve Kit	MHP4-09-12, 18, 24, & 30/MHP4-10-18 & 24
ASLEEVE2-2	2" Wall Sleeve Kit	MHP4-10-30/MHP4-09-36
ASLEEVE6-1	6" Wall Sleeve Kit	MHP4-09-12, 18, 24, & 30/MHP4-10-18 & 24
ASLEEVE6-2	6" Wall Sleeve Kit	MHP4-10-30/MHP4-09-36
ASLEEVE8-1	8" Wall Sleeve Kit	MHP4-09-12, 18, 24, & 30/MHP4-10-18 & 24
ASLEEVE8-2	8" Wall Sleeve Kit	MHP4-10-30/MHP4-09-36
ASLEEVE10-1	10" Wall Sleeve Kit	MHP4-09-12, 18, 24, & 30/MHP4-10-18 & 24
ASLEEVE10-2	10" Wall Sleeve Kit	MHP4-10-30/MHP4-09-36
ASLEEVE12-1	12" Wall Sleeve Kit	MHP4-09-12, 18, 24, & 30/MHP4-10-18 & 24
ASLEEVE12-2	12" Wall Sleeve Kit	MHP4-10-30/MHP4-09-36
ASLEEVE6-3	6" Wall Sleeve for 45" Louver	MHP4-09-24 & 30/MHP4-10-18 & 24
ASLEEVE6-4	6" Wall Sleeve for 45" Louver	MHP4-10-30/MHP4-09-36
ASLEEVE8-3	8" Wall Sleeve for 45" Louver	MHP4-09-24 & 30/MHP4-10-18 & 24
ASLEEVE8-4	8" Wall Sleeve for 45" Louver	MHP4-10-30/MHP4-09-36
ASLEEVE10-3	10" Wall Sleeve for 45" Louver	MHP4-09-24 & 30/MHP4-10-18 & 24
ASLEEVE10-4	10" Wall Sleeve for 45" Louver	MHP4-10-30/MHP4-09-36
ASLEEVE12-3	12" Wall Sleeve for 45" Louver	MHP4-09-24 & 30/MHP4-10-18 & 24
ASLEEVE12-4	12" Wall Sleeve for 45" Louver	MHP4-10-30/MHP4-09-36
AFILTMP-1	Outdoor Coil Filter Kit	All Models
AADAPTPVC412-1	Threaded PVC Nipple	All Models

² Thru-the-wall installations only

Wall Sleeve Dimensions (in.)

Kit No.	A	B	C	D
ASLEEVE2-1	2	29	29-1/8	29-1/8
ASLEEVE2-2	2	32-3/4	32-7/8	29-1/8
ASLEEVE6-1	6	29	29-1/8	29-1/8
ASLEEVE6-2	6	32-3/4	32-7/8	29-1/8
ASLEEVE6-3	6	45	45-1/8	29-1/8
ASLEEVE6-4				
ASLEEVE8-1	8	29	29-1/8	29-1/8
ASLEEVE8-2	8	32-3/4	32-7/8	29-1/8
ASLEEVE8-3	8	45	45-1/8	29-1/8
ASLEEVE8-4				
ASLEEVE10-1	10	29	29-1/8	29-1/8
ASLEEVE10-2	10	32-3/4	32-7/8	29-1/8
ASLEEVE10-3	10	45	45-1/8	29-1/8
ASLEEVE10-4				
ASLEEVE12-1	12	29	29-1/8	29-1/8
ASLEEVE12-2	12	32-3/4	32-7/8	29-1/8
ASLEEVE12-3	12	45	45-1/8	29-1/8
ASLEEVE12-4				
ASLEEVE-3*	*	45	45-1/8	29-1/8

* Thru-the-wall installations only

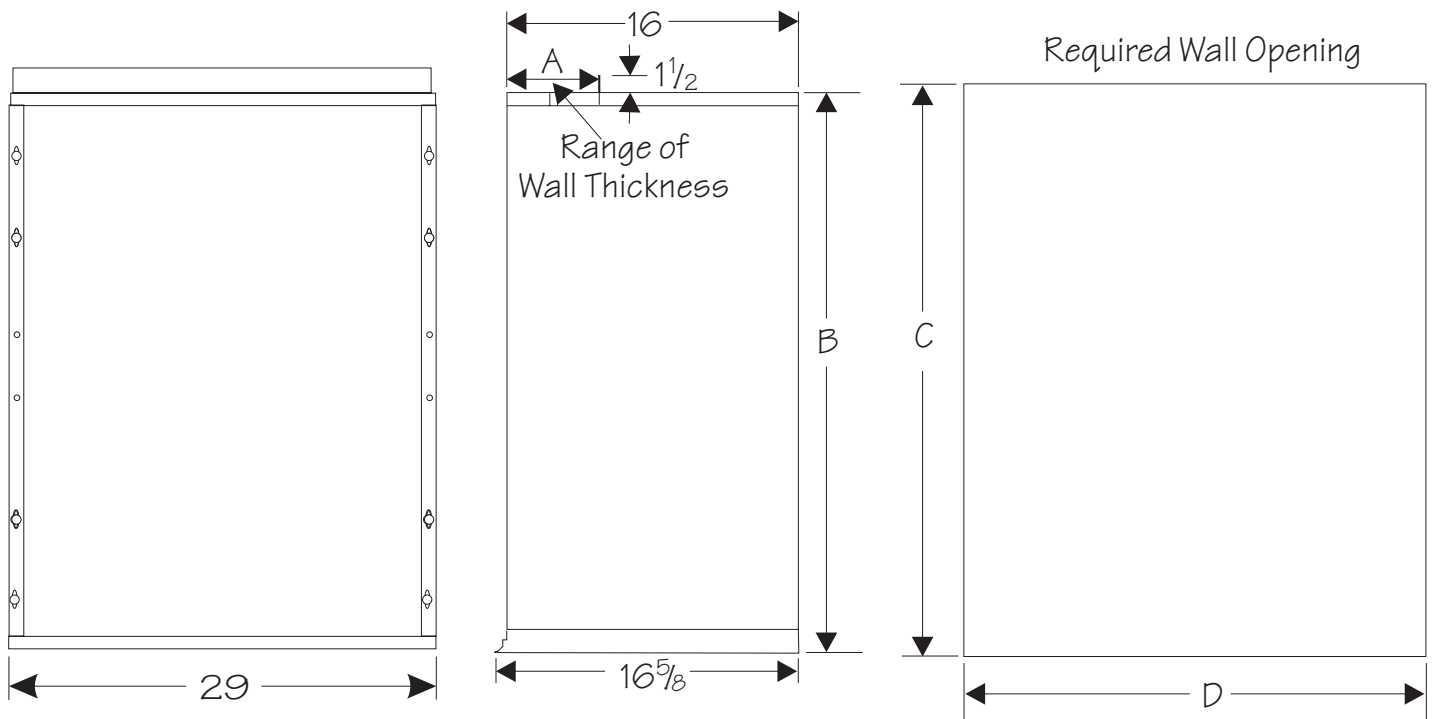

NOTE: Bottom surface of wall opening must be at least 4" off the floor.

⚠ WARNING

The unit must be installed with approved wall sleeve and grille accessories for safe operation. Improper installations could result in property damage, personal injury, or death.

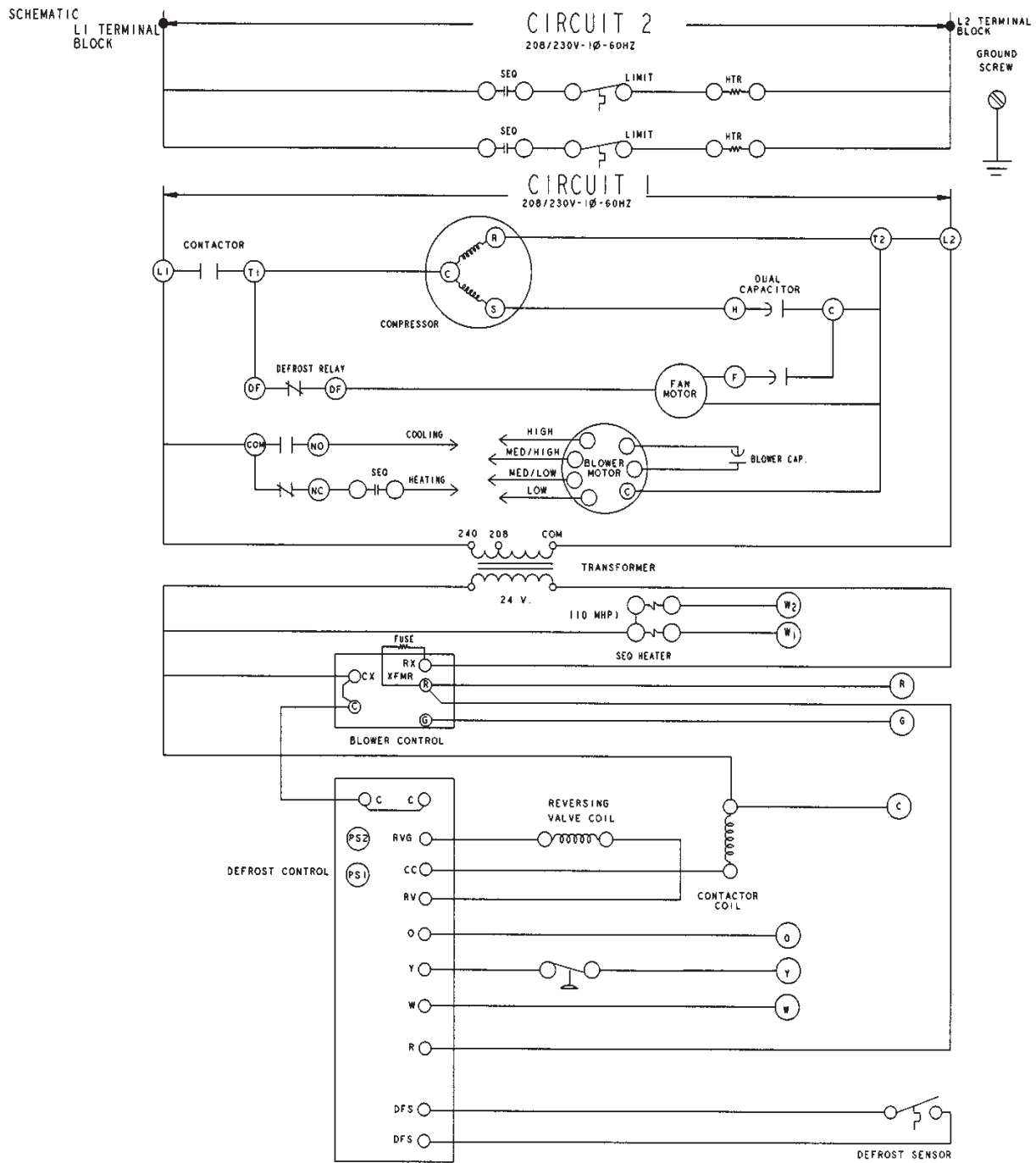

537246-01

**Schematic Diagram
#537246-01**

Figure 13

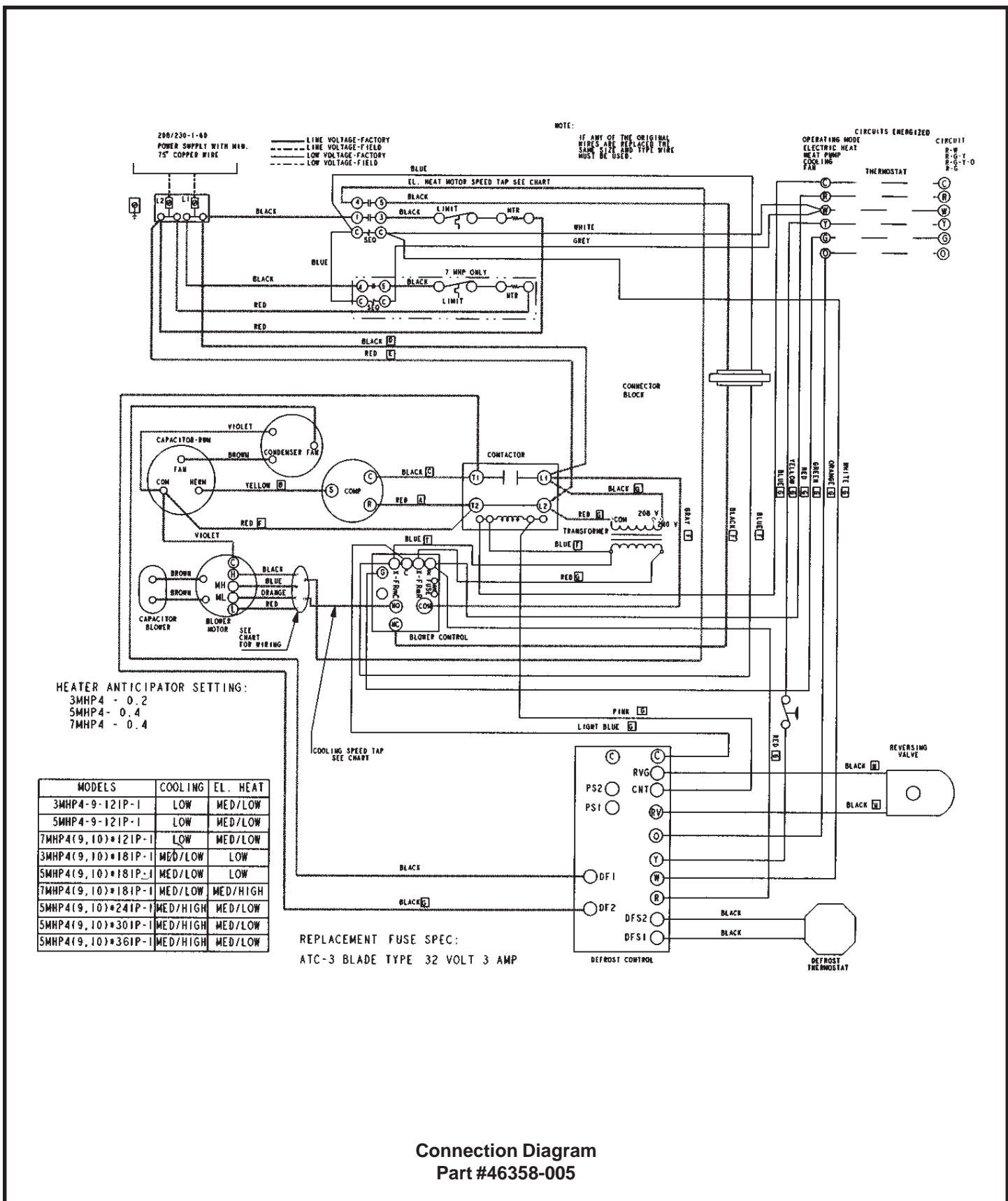

Connection Diagram
Part #46358-005

Figure 14

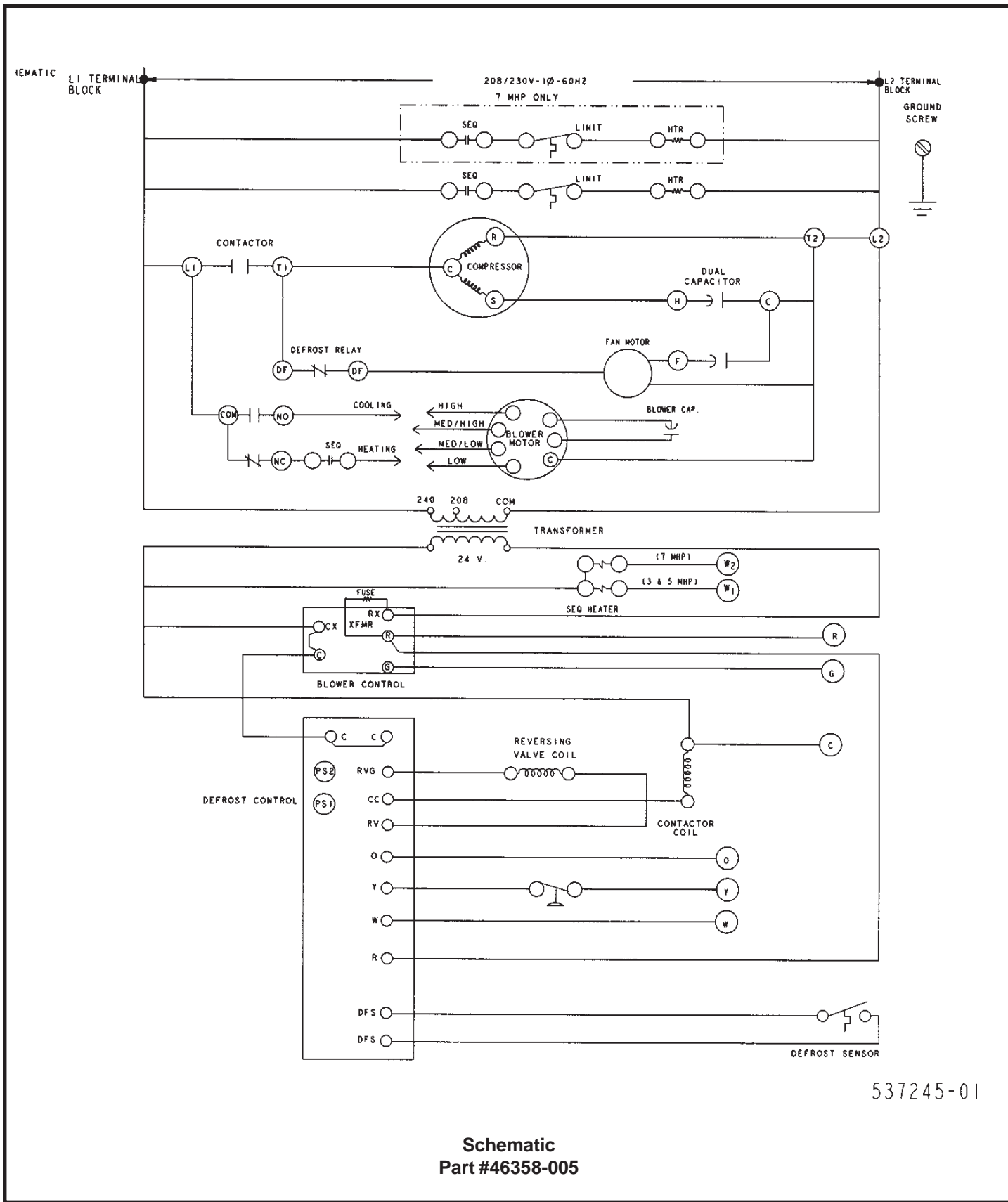

537245-01

Schematic
Part #46358-005

Figure 15

NOTES